

Parks, Recreation & Culture Advisory Committee
Agenda for Meeting to be held on
Wednesday, September 21th, 2022 at 7:00pm
Frank Jameson Community Centre at 810 6th Avenue

The goal of the Parks, Recreation and Culture Advisory Committee is to provide advice and recommendations to Council regarding the establishment and implementation of Parks, Recreation and Culture priorities in the Town of Ladysmith.

1. Call to Order and Acknowledgement

The Town of Ladysmith acknowledges with gratitude that this meeting takes place on the traditional, unceded territory of the Stz'uminus First Nation.

2. Agenda Approval

3. Minutes

- a) Minutes of the meeting held May 18th, 2022

4. New Business

- a) New Members Welcome
b) Elect Chair and Co-Chair
c) Civic Recognition Program

CS 2022-073

That Council refer the "Civic Recognition" program to the Parks, Recreation & Culture Advisory Committee to develop a draft policy for Council's consideration.

Motion Carried

- d) Community Banner Program PATG Report

- e) Ladysmith Skatepark
- RDS Granite Mission Program
 - Request for support letter

5. Old Business

- a) Items postpone until October
- Park Implementation Plan – Review engagement/capture improvements

6. Adjournment

Minutes of the Parks, Recreation & Culture Advisory Committee
Wednesday, May 18, 2022 at 7:00pm
Frank Jameson Community Centre

COMMITTEE MEMBERS PRESENT:

Tim Richards, Chair
Lynda Baker
Bruce Mason
Lucy Partington
Councillor Duck Paterson

STAFF PRESENT:

Chris Barfoot, Lead
Kim Cheang, Minute Taker

REGRETS:

Kelly Daniels
Geoff Dean
Jacqueline Huard
Lesley Lorenz
Emily Weeks

GUESTS:

Germain Badke
Tim Fletcher
Charlene Manner
Jesse Manner

**CALL TO ORDER AND
ACKNOWLEDGEMENT**

The Chair called the meeting to order at 7:03pm and acknowledged with gratitude that this meeting takes place on the traditional, unceded territory of the Stz'uminus First Nation.

AGENDA

2022-16:
That the Parks, Recreation & Culture Advisory Committee approve the agenda for the meeting as presented.
Motion Carried.

MINUTES

2022-17:
That the Parks, Recreation & Culture Advisory Committee approve the minutes of the May 4, 2022 meeting as presented.
Motion Carried

NEW BUSINESS

1. Delegation: Ladysmith Skatepark Community Interest Group

J. Manner and T. Fletcher made a presentation entitled "Why Us? Why Now? Our Vision, and What's wrong with Ladysmith Skatepark?"

The group would like to form a committee to explore improvements to Ladysmith's skatepark. Many other regional district have recognized the need for and invested in their own skateparks. The park should be an inclusive experience to create a safe and enjoyable modern skatepark for all ages and abilities. An opportunity for fun/outdoor/subconscious physical activity for health of the youth.

The group feels that there are some safety concerns that need to be addressed such as the sharp change of gradient, wheels can get stuck in the cracks, the box is too close to the quarter pipes in a high speed area. The design is a very open layout with a lack of features to maintain momentum throughout the skatepark.

The Committee provided the following feedback to the delegation:

1. Work on the concept plan i.e. design, elements, features with budget and some possibilities to create a preliminary vision to help get to the next step.
2. Make the public aware of the project and begin fundraising through service clubs and community groups.
3. Distinguish between the maintenance problems that are safety related versus the design issues i.e. list of maintenance issues with photo of each in order to request increased funding from the Town (short term plan).

2. Park Implementation Plan: In-Person Engagement

The Committee discussed engaging and interactive activities such as:

1. Stops with map and information similar to self-guided tours focusing on:
 - Entry point
 - Playground
 - Storybook walk
 - Trails through the forest
 - Creek
 - Open space
2. Hot dogs and coffee at the end of the event.

PRC DEPARTMENT UPDATE

C. Barfoot provided a department update including:

- April drop-in/scans admission
- Registration and participant numbers continue to be steady
- Program area projects: Youth Week, Storybook Walk
- Facility projects: canoe shelter, Kinsmen and Sportsmen shelter, Transfer Beach washrooms, concession building demolition, RGB Lighting and 2022 capital projects.

NEXT MEETING

7:00pm on Wednesday, June 15, 2022 at FJCC

ADJOURNMENT

2022-18:

That the Parks, Recreation & Culture Advisory Committee adjourn this meeting at 8:39pm.

Motion Carried

CIVIC RECOGNITION PROGRAM

Community Name	No. of Awards	Award Description
City of Mississauga	Four different awards	<p>1.Certificate of Recognition *Individuals or groups who have had an impact at the local, regional or provincial level through volunteering, exemplary actions, achievements and victories *Recognize significant milestones of individuals and organization such as 50th wedding anniversaries, 90th birthdays, 10 year business anniversaries and official business openings Council considers nominations for this award on an ongoing basis throughout the year.</p> <p>2.Civic Award of Recognition *Groups or individuals who have volunteered in their communities for ten or more years *Individuals, businesses or community groups who have worked towards removing barriers for people with disabilities *Individuals with national or international achievements in arts, sports or academia *Youth ages 14 to 24 who volunteer for more than 100 hours in community and civic activities</p> <p>3.Civic Award of Merit The Civic Award of Merit is one of the highest forms of recognition that an individual can receive from the City of Mississauga. This award recognizes individuals whose achievements have made a major impact nationally or internationally. Only City Council can nominate someone for the Civic Award of Merit. Previous Civic Awards of Merit have been presented to Silken Laumann in 1992 and Oscar Peterson in 2003.</p> <p>4.Civic Philanthropy Award Two Civic Philanthropy awards are presented every year to individuals who've demonstrated an outstanding commitment and dedication to the City for a minimum of 25 years. Organizations are not eligible for the Civic Philanthropy Award.</p>

City of Prince Rupert	Six levels	<p>1. Freedom of the City represents the highest honour that the City can bestow on an individual or unit of the armed forces of Canada or another nation, in accordance with Section 158 of the Community Charter.</p> <p>2. Civic Merit Award represents an award bestowed on an individual who has brought distinction to the community through their outstanding achievement in one or more of the following areas: business and entrepreneurs, arts and entertainment, science and academics, health and education, sports and youth leadership and volunteer and community service.</p> <p>3. Sgt. William Booth Award For Valour represents an award presented to an individual who, acting on their own initiative or as members of volunteer organizations, demonstrate unusual humanitarian effort in order to help and protect their fellow citizens, sometimes placing themselves at great personal risk.</p> <p>4. Achievement Award represents an award presented to an individual, team, or group who, acting on behalf of the community, has achieved greatness in competitions at the provincial, national, or international level.</p> <p>5. Civic Appreciation Award represents the expression of appreciation to an individual and/or group for their services and/or contributions that have benefited the community.</p> <p>6. Certificate of Appreciation represents the expression of appreciation to an individual for their contribution to a Council established committee or task force to which they have been appointed.</p> <p>7. Appreciation Pin represents the expression of appreciation to an individual who has volunteered for a committee or the City for an event within the community.</p>
-----------------------	------------	--------------------------------------------------------------------------------------------------------------------------------------------------------------------------------------------------------------------------------------------------------------------------------------------------------------------------------------------------------------------------------------------------------------------------------------------------------------------------------------------------------------------------------------------------------------------------------------------------------------------------------------------------------------------------------------------------------------------------------------------------------------------------------------------------------------------------------------------------------------------------------------------------------------------------------------------------------------------------------------------------------------------------------------------------------------------------------------------------------------------------------------------------------------------------------------------------------------------------------------------------------------------------------------------------------------------------------------------------------------------------------------------------------------------------------------------------------------------------------------------------------------------------------------------------------------------------------------------------------------------------------------------------------------------------------------------------------------------------------------------------------------------------------------

<p>Town of Grimsby *The Town of Grimsby hosts a Civic Recognition Program every 2 years. The program is generally hosted in the Spring of even calendar years, and nominations become available a few months prior to the date.</p>	<p>Three category</p>	<p>1.Special Achievement Award *Citizens who have achieved Provincial, National or International Recognition and, in doing so, have brought honour to the Town of Grimsby. *Citizens who have completed special projects, voluntary in nature, that have brought favourable publicity to the community or that have contributed positively to the Grimsby community. *Citizens who have achieved a special milestone through community service efforts. (eg. 50th anniversary of a volunteer organization serving local purposes). 2.Outstanding Volunteer Award *Those who in the view of Town Council, have contributed significantly to the quality of life in the community through their volunteer efforts. 3.NEW - Outstanding Volunteer Award - COVID 19 Adapt and Recover *Citizens and community organizations who have contributed significant volunteer efforts towards Grimsby's COVID-19 recovery. (E.g. providing assistance and support to residents impacted by the pandemic.</p>
<p>Municipality of Port Hope</p>	<p>Nine available award</p>	<p>1.OUTSTANDING CITIZEN AWARD The Outstanding Citizen Award is presented to an individual in recognition of outstanding volunteer contributions in multiple areas within the community. The committee in selecting the recipient for the Outstanding Citizen award will consider: *length of service; *their demonstration of civic mindedness; *the benefits of their contributions to the community; *their service as a role model; *diversity of service; *leadership Additional Qualifications: *To be eligible for this award the nominee must be a resident of the Municipality of Port Hope; *The nomination form must be accompanied by a Signature Sheet, signed by a minimum of fifteen (15) adults. An Individual is eligible to be nominated in more than one (1) year; however, that individual shall not be eligible if they have previously been awarded the Outstanding Citizen Award within a 20 year timeframe.</p>

The recipient of the Outstanding Citizen Award shall be provided with the appropriate form of recognition as outlined below at the Civic Awards Ceremony.

2.OUTSTANDING YOUTH AWARD

The Outstanding Youth Award is presented to an individual in recognition of outstanding achievements and volunteer contributions within their school and community.

The committee in selecting the recipient for the Outstanding Youth Award will consider:

- *length of service;
- *their demonstration of civic mindedness;
- *the benefits of their contributions to the community;
- *their service as a role model;
- *diversity of service;
- *leadership.

Additional Qualifications:

- *Recipient must be nineteen (19) years of age or less as of December 31st of the year for which the award is given;
- *To be eligible for this award the nominee must be a resident of the Municipality of Port Hope;
- *The nomination form must be accompanied by a Signature Sheet, signed by a minimum of ten (10) people, at least five (5) must be adults.

An Individual is eligible to be nominated in more than one (1) year; however, that individual shall not be eligible if he/she has previously been awarded the Outstanding Youth Award.

The recipient of Outstanding Youth Award shall be provided with shall be provided with the appropriate form of recognition as outlined below at the Civic Awards Ceremony.

3.AGRICULTURE AWARD

The Agricultural Award is presented to the individual or group who is involved in a project that has had a considerable impact in the area of agriculture in the Municipality of Port Hope.

The committee in selecting the recipient(s) for the Agricultural Award will consider:

- *Degree of contribution in promoting agriculture in Port Hope;
- *Received an award in a provincial or higher agricultural competition during the year for which the Agricultural Award is presented;
- *Leadership and innovation within the agricultural community;

*Involvement within the community volunteering, teaching, promoting, or encouraging sustainable agriculture within the Municipality of Port Hope.
Previous recipients will be eligible for consideration if:
*Their achievement is in a different area than they were previously nominated for;
*Five (5) years have passed since their last award for the same achievement;
*If in the same category, they have significantly exceeded their previous achievement.

4.INSPIRATION AWARD

The Inspiration Award is presented to an individual who inspires those around them to serve more, to think bigger, who encourages action, is a strong source of support within the community, or pushes those around them to believe in themselves.

The committee in selecting the recipient for the Inspiration Award will consider:

- *Type and nature of the inspiration provided
- *Type and nature of the inspiration provided;
- *Number of people influenced;
- *Impact of their actions.

Previous recipients will be eligible for consideration if:

- *Their achievement is in a different area than they were previously nominated for;
- *Five (5) years have passed since their last award for the same achievement;
- *If in the same category, they have significantly exceeded their previous achievement.

5.PHILANTHROPY AWARD

The Philanthropy award is to be awarded to an individual, couple or group for their outstanding desire to promote the welfare of others through the generous donation of money, goods, talent or services.

The committee in selecting the recipient for the Philanthropy Award will consider:

- *The degree of benefits to the residents within the Municipality of Port Hope as a result of philanthropic contribution;
- *Leadership role in fundraising and the encouragement of other to give generously.

Previous recipients will be eligible for consideration if:

- *Their achievement is in a different area than they were previously nominated for;

- *Five (5) years have passed since their last award for the same achievement;
- *If in the same category, they have significantly exceeded their previous achievement.

6.ENVIRONMENT AWARD

The Environment Award is to be awarded to a person or group for outstanding leadership, inspiration, vision, innovation or action on behalf of environmental causes.

The committee in selecting the recipient for the Environment Award will consider:

- *Completed a local fundraising campaign to benefit a local environmental project;
- *Raised awareness for environmental issues (including media coverage);
- *Provided a benefit to the environment through increased conservation, through restoration of natural habitat, in the use of environmentally sound practices in construction or operations.

Previous recipients will be eligible for consideration if:

- *Their achievement is in a different area than they were previously nominated for;
- *Five (5) years have passed since their last award for the same achievement;
- *If in the same category, they have significantly exceeded their previous achievement.

7.ARTS & CULTURE AWARD

The Arts and Culture Award is to be awarded to an individual or groups for promotion or high achievement in the Arts and/or significant cultural contributions to the community.

The committee in selecting recipients will consider:

- *High achievements in the arts;
- *Their contribution to artistic excellence within the community;
- *Their leadership in teaching, encouraging, and engaging the public in cultural or artistic projects;
- *Projects that enhance the vitality and vibrancy of Port Hope.

Previous recipients will be eligible for consideration if:

- *Their achievement is in a different area than they were previously nominated for;
- *Five (5) years have passed since their last award for the same achievement;
- *If in the same category, they have significantly exceeded their previous achievement.

8.ATHLETICS AWARD

The Athletics Award is designed to recognize individuals or teams who have excelled within their particular sport.

Awarded to a team or individual that has met one or more of the following criteria:

- *Placed first, second or third in a national championship;
- *Placed first, second or third in a provincial championship;
- *Has been chosen to represent Ontario in a national competition;
- *Has been chosen to represent Canada in an international competition.

Given the level of achievement, previous year's award recipients may be eligible for consideration.

9.COMMUNITY SERVICE AWARD

The Community Service award recognizes individuals or groups who positively impact the Municipality of Port Hope through their volunteerism by enhancing quality of life for others.

The committee in selecting recipients will consider:

- *Demonstrable impact on the community in the service of making Port Hope a better place to live;
- *Multiple areas of volunteerism;
- *Project leadership;
- *Length of service.

Volunteers who have volunteered solely for a one-day will not be considered for this award.

Previous recipients will be eligible for consideration if:

- *Their achievement is in a different area than they were previously nominated for;
- *Five (5) years have passed since their last award for the same achievement;
- *If in the same category, they have significantly exceeded their previous achievement.

Service Organization recipients to be based upon 5 year increments of membership and service. Consideration to an exception may be provided for an activity that meets the Impact on Community requirement in an exceptional and outstanding way.

SPECIAL COMMENDATION

The Civic Awards Committee and Council have the authority to provide special accommodation to a nomination that does not neatly fit any of the existing award categories and implement the Special Commendation Award.

		This award is not open for nominations, but a special certificate can be prepared and presented if the Committee and Council deem appropriate.
City of Duncan	3 award	<p>1.PERPETUAL TROPHY FOR EXCELLENCE & SPORTSMANSHIP The Perpetual Trophy for Excellence & Sportmanship recognizes one individual or organization that has:</p> <ul style="list-style-type: none"> *contributed significant time and effort to support a Cowichan Valley; *demonstrated an outstanding degree of sportsmanship; or *contributed substantial time and effort to support sports through volunteer service. <p>2.SCROLL OF HONOUR We value the volunteers in our community! The City’s Scroll of Honour Award recognizes individuals who have demonstrated at least 15 years of service in the Cowichan Valley.</p> <p>3.PERPETUAL ARTS TROPHY The Perpetual Arts Trophy recognizes one individual:</p> <ul style="list-style-type: none"> *who has demonstrated excellence in the performing, literary or visual arts; *whose contributions to arts education have produced visionary creative work; *who has contributed significant time and effort to support a Cowichan Valley based artist or arts organization through volunteer service; or who has demonstrated outstanding promise and commitment to the Cowichan Valley arts community.

REPORT TO PARKS, RECREATION & CULTURE ADVISORY COMMITTEE

Report Prepared By: Shannon Wilson, Staff Liaison to PATG
Chris Barfoot, Director, Parks, Recreation & Culture
Meeting Date: September 21, 2022
RE: **2023 COMMUNITY BANNER PROGRAM - THEME
RECOMMENDATION**

RECOMMENDATION:

That the Parks, Recreation & Culture Advisory Committee endorse the recommendation of the Public Art Task Group and recommend that Council:

1. Approve the theme “Connecting Ladysmith Through the Arts” for the 2023 Community - Public Art Banners.

EXECUTIVE SUMMARY:

The purpose of the Community Banner Program is beautification and community identity promotion. Community banners add vibrancy and community spirit throughout Ladysmith and will represent Ladysmith’s small town charm, coastal community life and diverse cultural heritage. The Public Art Task Group (PATG) recommends themes for the program and makes its recommendations to Council through the PRCAC as per the group’s Terms of Reference.

The Community Banner Program showcases the downtown core, and the Transfer Beach Boulevard.

Purpose of PATG and Coordination of the Community Banner Program

In November 2020, the PATG was formed. The purpose of the PATG is to assist the Town with:

- Providing advice and recommendations to Council on specific Public Art projects, including selection processes, acceptance of grants, gifts, donations, bequests and deaccession.

The PATG has two functions:

- (a) To advise the Town on public art issues and trends relevant to public art initiative in Town.

(b) To advise on specific issues, such as donations, deaccession, and commissions of work.

The PATG will review matters as outlined within the purpose of the PATG, and make recommendations to Council through the Parks, Recreation & Culture Advisory Committee.

In consultation with the PATG, Staff will manage the Community Public Art Banner Program. The PATG will recommend the theme for the Banner Program to Council through PRCAC and the PATG will strike a selection panel to choose and recommend the Public Art Banners to Council through the PRCAC.

THEME RECOMMENDATION

The PATG recommends a theme that showcases art that connects people, promotes peace, spreads positivity, creates opportunities to be together, focuses on relationships, and celebrates diversity. Ladysmith and Stz'uminus' natural environment inspires creativity, and community events and gatherings create the connections we all need to feel a sense of belonging.

The Public Art Task Group recommends the 2023 banner theme of “**Connecting Ladysmith through the Arts**” for consideration by the PRCAC.

Zone	Banners	2023 Theme
Zone 1-4	Community Public Art	Connecting Ladysmith Through the Arts
Zone 5	Community Seasonal -Town	J. Harris Designs

*Map shown in Attachment A

INTRODUCTION/BACKGROUND:

There are approximately 160 banners throughout Ladysmith. Current locations of the banners are in the downtown core and Transfer Beach Boulevard.

The Community Public Art Banner Program for 2023 includes new designs in the downtown core along First Avenue from Symonds Street to Robert Street.

The annual Public Art Banner themes will be recommended, and presented to Council for consideration. Once the theme is confirmed, the Call for Artists process will commence.

Each year, banners are displayed from May to October. The Community Banner Program has an annual budget allocation.

FINANCIAL IMPLICATIONS:

The existing annual operational funding for the banners will be used for the Community Banner Program. It is not anticipated that additional funding would be required. Existing funding would continue to cover artists fee, as well as design and production costs.

ATTACHMENT:

- A. Community Banner Map

COMMUNITY BANNER PROGRAM MAP

- Zone 1
- Zone 2
- Zone 3
- Zone 4
- Zone 5
- Directional Banners



RDS Granite Mission

More and more of our RDS granite benches continue to be produced and are getting delivered to selected spots across Canada!



How it Works:

If you're interested in getting one of them donated and delivered to your local public skatepark or other suitable public area, please email us at online@reddragonapparel.com with the following criteria that must be met:

1. Location (Suitable space like a skatepark or public area)
2. Open to the public and accessible by everyone
3. Approved by the city or land owner.

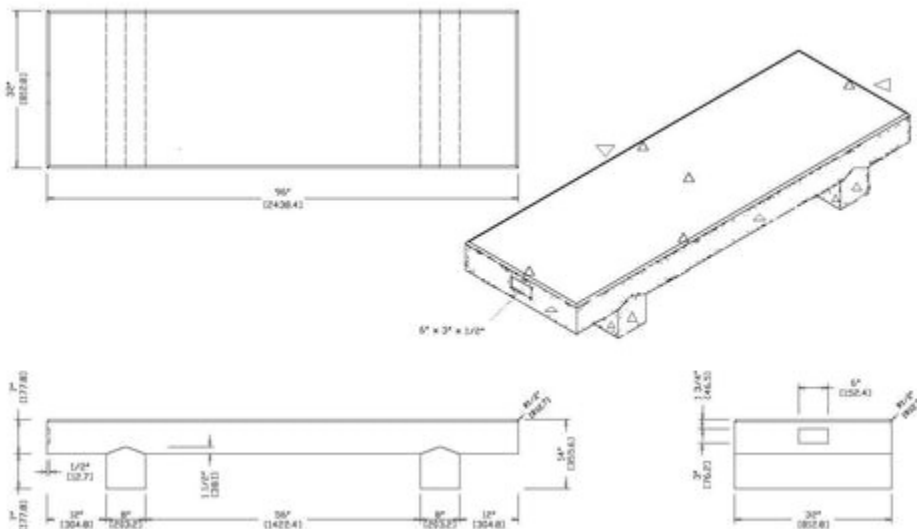

We'll also need your local expertise and connections to clear the way with the local officials in charge of approving the potential installation! Good luck!

#supportcanadianskateboarding #RDSGranite

