

PLAN

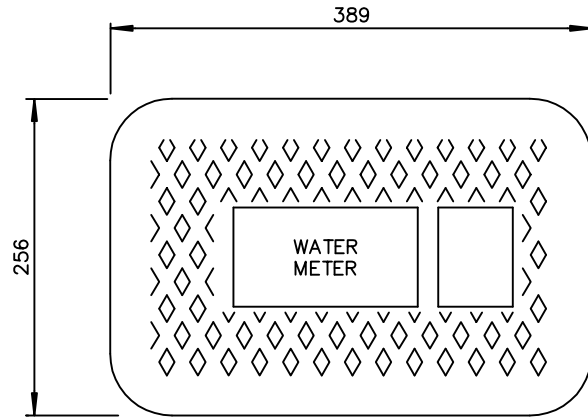

COVER

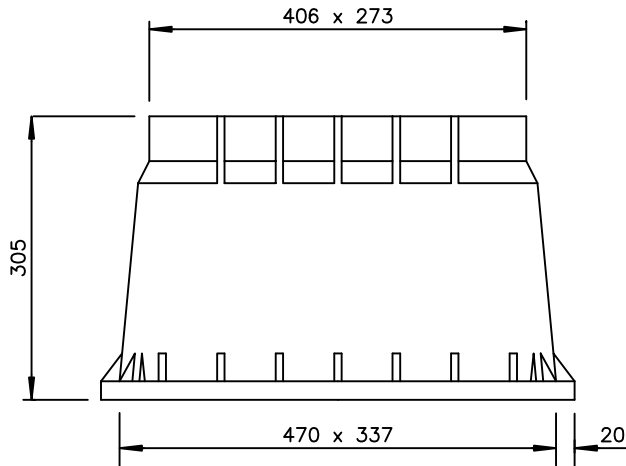

STANDARD METER BOX  
ELEVATION

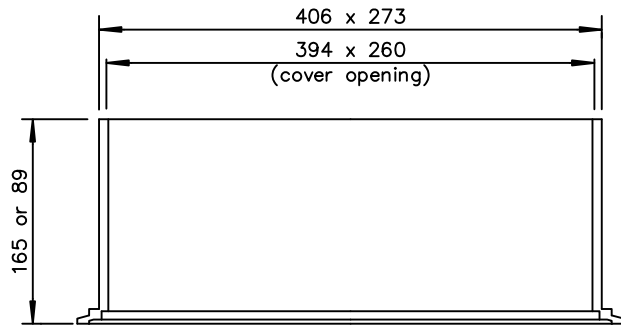

METER BOX EXTENSION

NOTES:

1. FOR 25 $\phi$  SERVICES IN UNTRAVELED AREAS USE JUMBO METER BOX WITH 355 x 510 COVER OPENING
2. ONLY PRODUCTS APPROVED BY THE TOWN ENGINEER WILL BE ACCEPTED FOR INSTALLATION

DIMENSIONS ARE IN MILLIMETRES UNLESS OTHERWISE NOTED



**TOWN OF LADYSMITH**  
ENGINEERING STANDARD

PLASTIC METER BOX  
FOR 19mm $\phi$  SERVICES

DATE: FEB. 1994

APP. BY:

DRAWING No.  
**W10**

REV.  
**00**