

HEAVY DUTY MANHOLE FRAME AND COVER
(STD. DWG. No. S4). PROJECT FRAME
0 IN PAVEMENT
25 IN UNPAVED AREAS

MAX. 3. MIN. 1 COURSE OF
BRICK OR PRECAST CONCRETE
RISER RINGS LAID IN PORTLAND
CEMENT MORTAR.

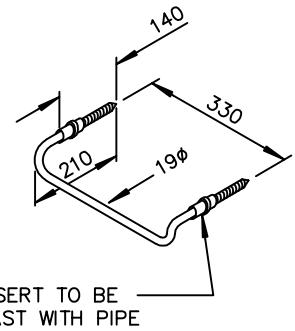

INSERT TO BE
CAST WITH PIPE

GALVANIZED OR ALUMINUM
LADDER RUNG

CONCRETE

CONCRETE COVER SLAB
TO CS600 LOADING

175

1-300 SECTION REQUIRED

JOINTS TO BE WATERTIGHT,
MORTAR OR O-RING JOINTS

19 ϕ RUNGS AT 300 o/c
CAST IN WALL OF BARREL
INSTALL IN CONFORMANCE
WITH W.C.B. REQUIREMENTS.

PRECAST REINFORCED CONCRETE
BARREL CONFORMING TO ASTM C478
MINIMUM DIAMETER 1050

RUBBER MANHOLE
ADAPTOR RING
(PLASTIC PIPE
ONLY)

450
(MAX.)

CONCRETE BASE
SEE DETAIL

WHERE MANHOLE BASE EXCAVATION EXTENDS
BEYOND BASE DIMENSION, THE OVEREXCAVATION
SHALL BE FILLED WITH CONCRETE TO 100
BELOW THE BOTTOM OF THE PIPE AND FOR
THE WIDTH OF THE TRENCH

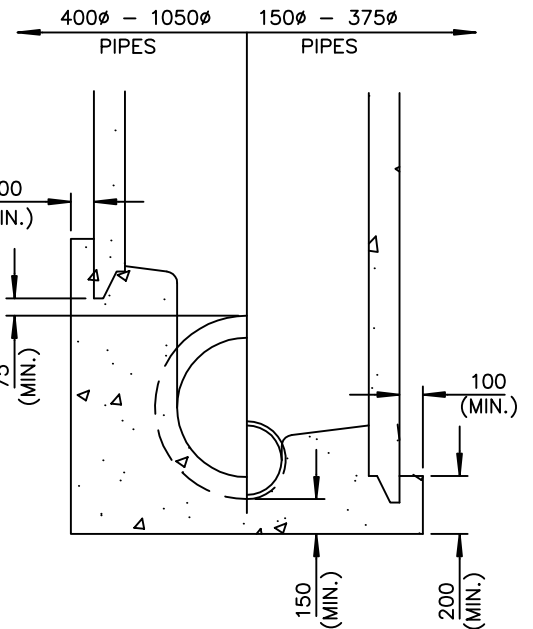

NOTES:

1. FOR MANHOLE BENCHING DETAILS
SEE STANDARD DRAWING No. S1
2. ONLY PRODUCTS APPROVED BY THE ENGINEER
WILL BE ACCEPTED FOR INSTALLATION

WHERE POSSIBLE USE HALF SECTIONS,
OR BREAK OUT TOP HALF OF PIPE

PLASTIC PIPE TO TERMINATE IN
MANHOLE WALL WITH RUBBER
MANHOLE ADAPTOR RING

DIMENSIONS ARE IN MILLIMETRES UNLESS OTHERWISE NOTED



TOWN OF LADYSMITH
ENGINEERING STANDARD

TYPICAL MANHOLE DETAILS
STANDARD PRECAST TYPE

DATE: JAN. 1999

APP. BY:

DRAWING No.

S2

REV.

01