

EXTENSION

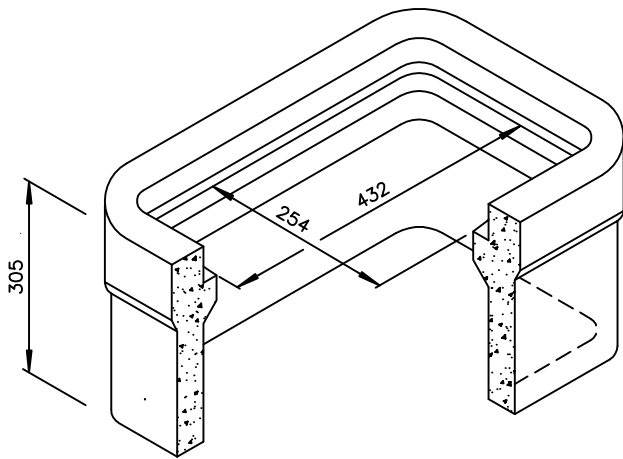

TOP

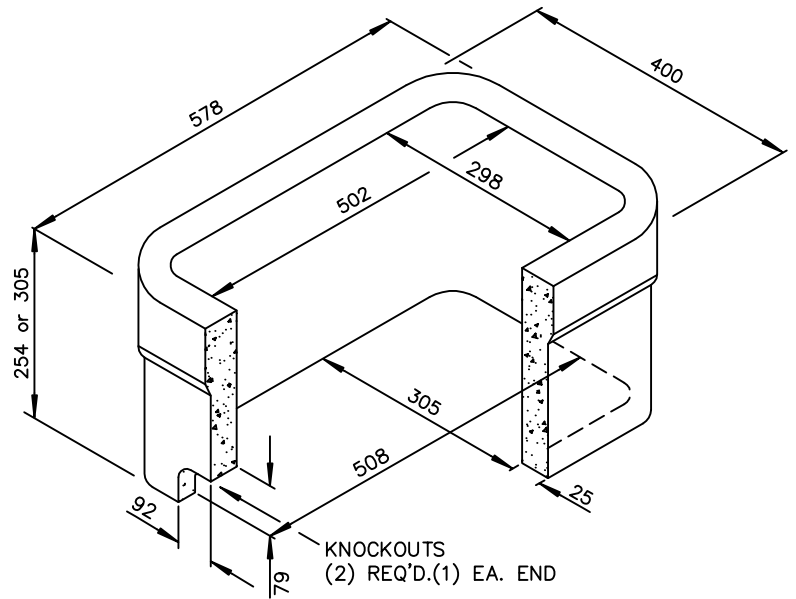

BOTTOM

NOTES

1. ONLY PRODUCTS APPROVED BY THE TOWN ENGINEER WILL BE ACCEPTED FOR INSTALLATION

DIMENSIONS ARE IN MILLIMETRES UNLESS OTHERWISE NOTED



**TOWN OF LADYSMITH**  
**ENGINEERING STANDARD**

**SINGLE SERVICE**  
**CONCRETE BOX**

DATE: FEB. 1994

APP. BY:

DRAWING No.

**D7**

REV.

**00**